

ナニワ規格シャックル:SAシャックル

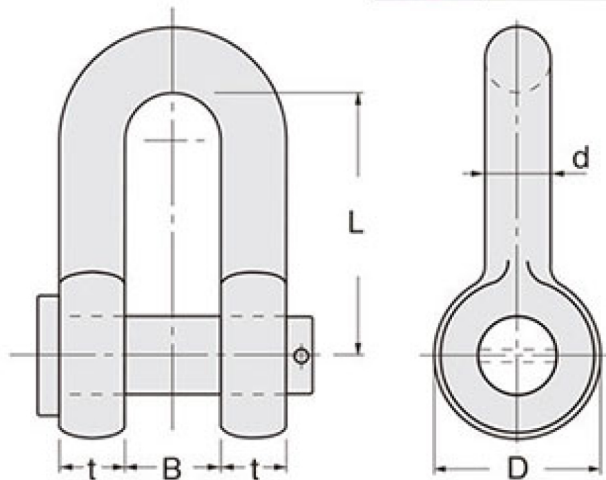

■寸法図

型式	SA
サイズ	34mm~90mm



() 寸法はJISに準ずる 単位: mm

呼び	使用荷重		t・d	B (口幅)	D (頭径)	L (長さ)	穴径	ピン径	ねじ径	重量(kg)		
	tf	kN								SC	SB	SA
6	0.2	1.96	6	11	17	24	9	8	M8	0.04	—	—
8	0.35	3.43	8	14	21	32	11	10	M10	0.08	—	—
10	0.6	5.88	10	17	25	40	13	12	M12	0.14	(0.3)	—
12	0.9	8.82	12	20	32	48	16	15	M14	0.28	(0.35)	—
14	1.2	11.76	14	24	36	56	18	17	M16	0.4	(0.5)	—
16	1.5	14.7	16	26	40	64	20	19	M18	0.57	(0.65)	—
18	2	19.6	18	29	45	72	22	21	M20	0.78	(0.9)	—
20	2.5	24.5	20	31	50	80	25	24	M24	1.05	1.3	—
22	3	29.4	22	34	55	88	27	26	M24	1.5	1.9	—
24	3.6	35.28	24	39	62	96	31	30	M30	2.1	2.6	—
26	4.2	41.16	26	41	66	104	33	32	M30	2.5	2.9	—
28	4.8	47.04	28	43	70	112	35	34	M33	3.0	3.6	—
30	5.4	52.92	30	45	75	120	37	36	M36	3.7	4.4	—
32	6.2	60.76	32	48	80	128	39	38	M36	4.5	5.1	—
34	7	68.6	34	50	85	136	41	40	M39	5.2	6.2	5.6
36	8	78.4	36	54	90	144	43	42	M42	6.5	7.5	6.7
38	9	88.2	38	57	95	152	47	46	M45	7.5	9.0	7.8
40	10	98	40	60	100	160	49	48	M48	8.8	10.6	9.0
42	11	107.8	42	63	105	168	53	51	M48	—	11.9	10.6
44	12	117.6	44	66	110	176	56	54	M48	—	13.4	12.5
46	13	127.4	46	68	115	184	58	56	M48	—	15.0	13.7
48	14	137.2	48	72	120	192	60	58	M56	—	17.9	15.5
50	15	147	50	75	125	200	62	60	M56	—	19.9	18.1
55	18	176.4	55	83	138	220	67	65	M64	—	26.5	24.6
60	22	215.6	60	90	150	240	72	70	M64	—	33.0	32.0
65	26	254.8	65	98	164	260	79	77	M72	—	42.9	39.0
70	30	294	70	105	178	280	85	83	M80	—	56.0	49.8
75	35	343	75	112	192	300	92	90	M80	—	65.6	62.0
80	40	392	80	120	206	320	98	96	M90	—	83.0	75.0
85	45	441	85	128	220	340	104	102	M90	—	94.7	90.0
90	50	490	90	135	232	360	110	108	M100	—	115.0	105.0